

THIS DRAWING AND DESIGN HEREON CONSTITUTES A PROPRIETARY DESIGN OF PACKARD ELECTRIC DIVISION AND IS NOT TO BE DUPLICATED OR REPRODUCED EXCEPT TO PRODUCE GOODS AND SERVICES TO GENERAL MOTORS CORP.  
DO NOT SCALE

PART NO  
1205 2139

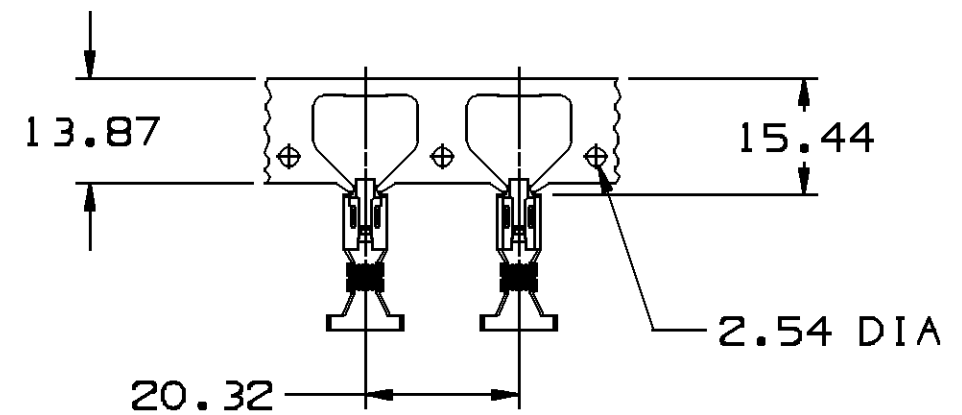

CARRIER STRIP VIEW  
SCALE 2:1

DATE	SYM	REVISION RECORD	AUTH	DR	CK
13AP93	-	REDRAWN & REVISED			
		REV LEVEL REMAINS			
		AT "J"	154495	DE	DE
30JN93	K	REV LEVEL ADVANCED	154898	RLB	BKD
14FE96	-	20.0+0.3/-0.6 DIM			
		WAS 20.0	168490	HH	HH
16MR96	-	REVISED	164943	JVS	JVS
01AU06	K3	MAT'L SPEC WAS 425 TIN			
		BRS EX HD SN PLTD	283052	MDH	JAA

PART NO  
1205 2139

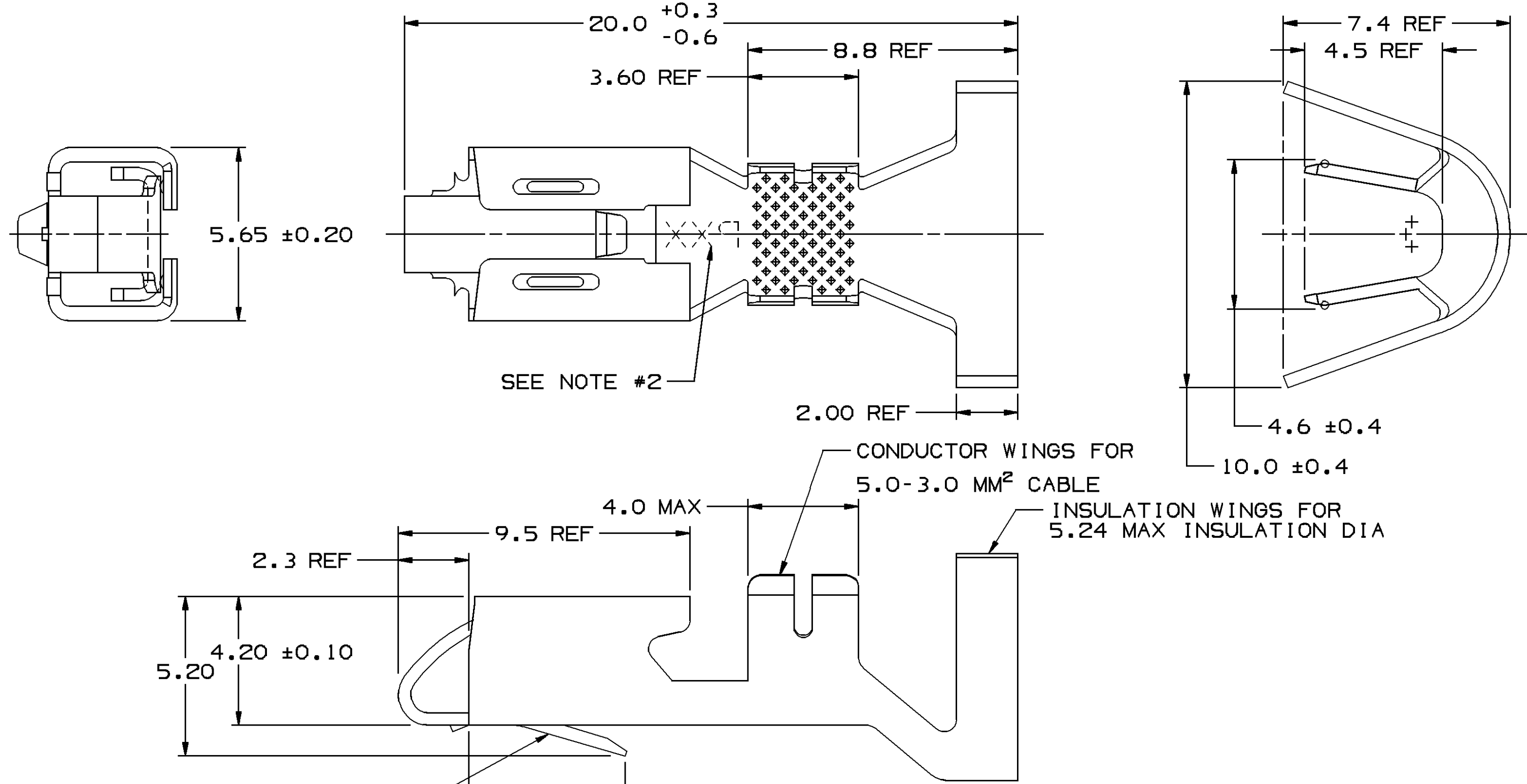

TANG FOR LOCKING TERMINAL IN CONNECTOR BODY

NOTES:

1. RECOMMENDED MATING BLADE 0.81 X 4.80 WIDE.
2. "PXX" INDICATES "P" PLUS LAST TWO DIGITS OF MAKE DIE SERIES NUMBER (P01, P02, P03, ETC).
3. TERMINALS TO HAVE TERMINAL ENGAGE OF 8N TO 28N WHEN MATED TO A 4.80 X 0.81 HARDENED STEEL BLADE.
4. REF GAGE #G-6904
5. DIMENSIONS MARKED "REF" ARE FOR REFERENCE ONLY AND NO TOLERANCE LIMITS ARE ESTABLISHED.
6. UNLESS OTHERWISE SPECIFIED AND/OR INDICATED: DIMENSIONS ARE TO FACE OF VIEW SHOWN AND AUTOMATICALLY ROUNDED BY COMPUTER FOR INSPECTION.

PACKARD ELECTRIC DIVISION  
GENERAL MOTORS CORPORATION  
WARREN, OHIO

		<b>METRIC</b> DIMENSIONS ARE IN MILLIMETERS UNLESS OTHERWISE SPECIFIED	
THIRD ANGLE PROJECTION 		TOLERANCE UNLESS OTHERWISE SPECIFIED DECIMAL: ANGULAR ± 2° ONE PLACE ± 0.3 TWO PLACE ± 0.15 DES	
CODE NO	QC	DR D. PAXSON	180CB4
6900		CK D. PAXSON	180CB4
DWG DATE	10SE84	APPR K. GRZENA	21NOB4
SCALE	NONE	VOL CM <sup>3</sup>	
REFERENCE NO	SHT #01	MATERIAL SPEC	
12088010 "R5" SIZE		M1574028 NONFERROUS C42500 EX HD	
NAME			
TERM F M/P 480			
PART NUMBER		SIZE	
1205 2139		A2	
PRODUCT INFORMATION DWG			