

ASSEMBLY INSTRUCTIONS PULL-TO-SEAT SEALED CONNECTION SYSTEM

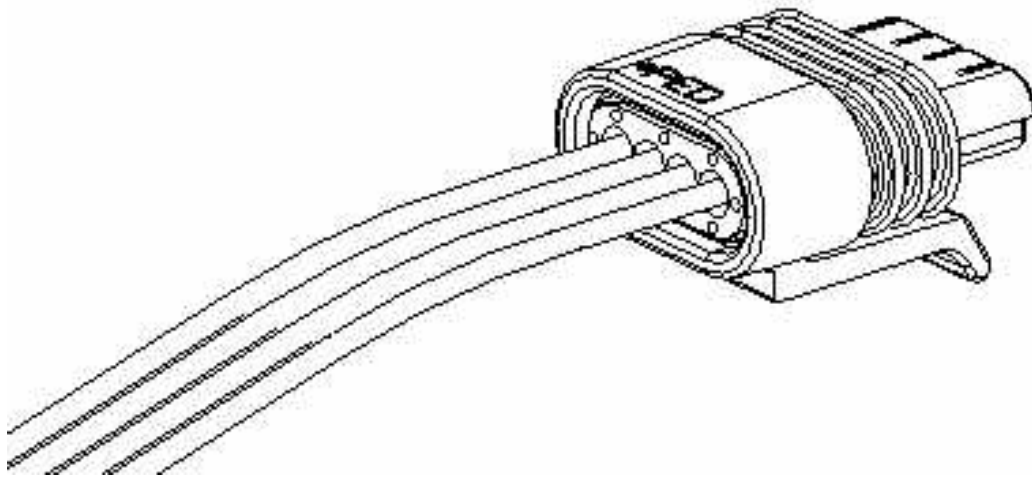

NOTE: PLEASE CONTACT YOUR DELPHI SALES REPRESENTATIVE WITH ANY QUESTIONS OR COMMENTS CONCERNING THESE ASSEMBLY INSTRUCTIONS. COMPONENT P/N'S AND REPAIR TOOL P/N'S ARE AVAILABLE FROM YOUR DELPHI SALES ENGINEER.

ASSEMBLY INSTRUCTIONS PULL-TO-SEAT SEALED CONNECTION SYSTEM

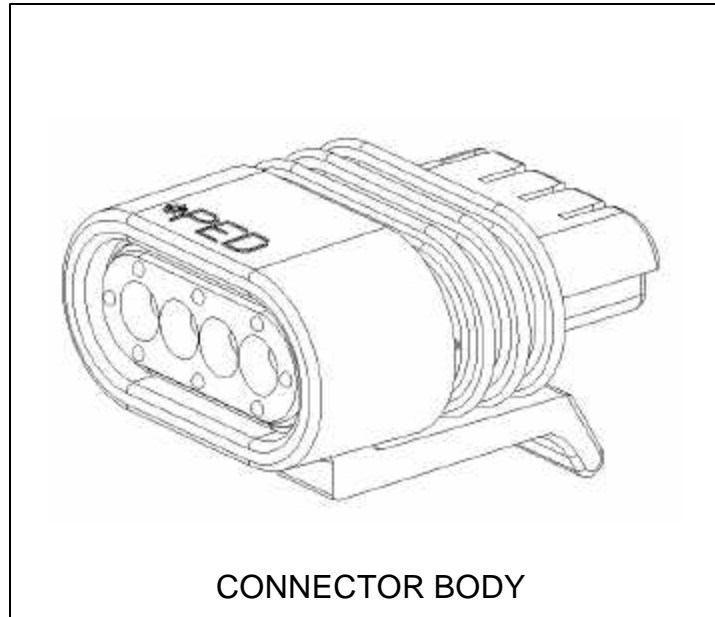

ASSEMBLY INSTRUCTIONS PULL-TO-SEAT SEALED CONNECTION SYSTEM

STEP 1: GET CONNECTOR ASSEMBLY AND HOLD SUCH THAT CABLE SEAL IS FACING ASSEMBLY OPERATOR. TAKE EACH CUT LEAD AND START THROUGH CABLE SEAL. **NOTE:** LEADS MUST BE BLUNT CUT FOR THIS OPERATION.

STEP 2: PUSH ALL LEADS THROUGH CABLE SEAL AND OUT THE OTHER END OF CONNECTOR ASSEMBLY. FROM THE BLUNT CUT END OF THE LEADS, PULL ALL LEADS THROUGH CONNECTOR ASSEMBLY A MINIMUM OF (8") FOR EASE IN SUBSEQUENT INSULATION STRIPPING AND TERMINATING PROCESSES.

STEP 3: STRIP EACH LEAD TO THE REQUIRED STRIP LENGTH FOR THE TERMINAL BEING APPLIED.

STEP 4: TERMINATE EACH LEAD WITH THE SPECIFIED TERMINAL.

STEP 5:

- A. PULL TERMINATED LEADS BACK THROUGH CONNECTOR ASSEMBLY TO FULLY SEATED POSITION IN CONNECTOR ASSEMBLY. USE CARE TO ALIGN TERMINAL IN CORRECT ORIENTATION AS IT MOVES INTO TERMINAL CAVITY. VERIFY THE TERMINAL HAS BEEN FULLY SEATED WITH THE AUDIBLE CLICK OF THE TANG.
- B. VISUALLY VERIFY THE FULLY SEATED TERMINAL AS IT SITS INSIDE THE PLASTIC TERMINAL CAVITY.
- C. IF CABLE SEAL PULLS OUT OF CONNECTOR ASSEMBLY DURING TERMINAL SEATING OPERATION, USE CARE TO PUSH SEAL BACK INTO POSITION IN CONNECTOR ASSEMBLY.

ASSEMBLY INSTRUCTIONS PULL-TO-SEAT SEALED CONNECTION SYSTEM

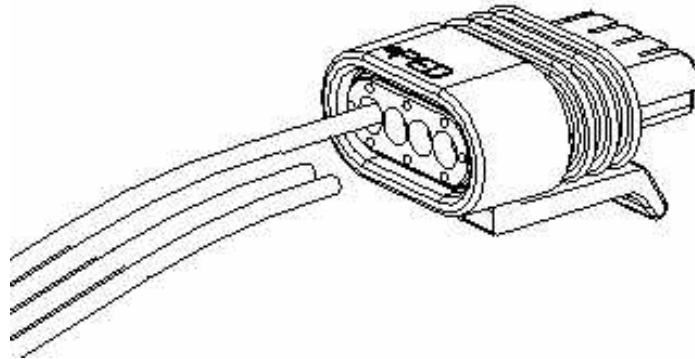

STEP 1: GET CONNECTOR ASSEMBLY AND HOLD SUCH THAT CABLE SEAL IS FACING OPERATOR. TAKE EACH BLUNT CUT LEAD AND START THROUGH CABLE SEAL.
NOTE: LEADS MUST BE BLUNT CUT FOR THIS OPERATION.

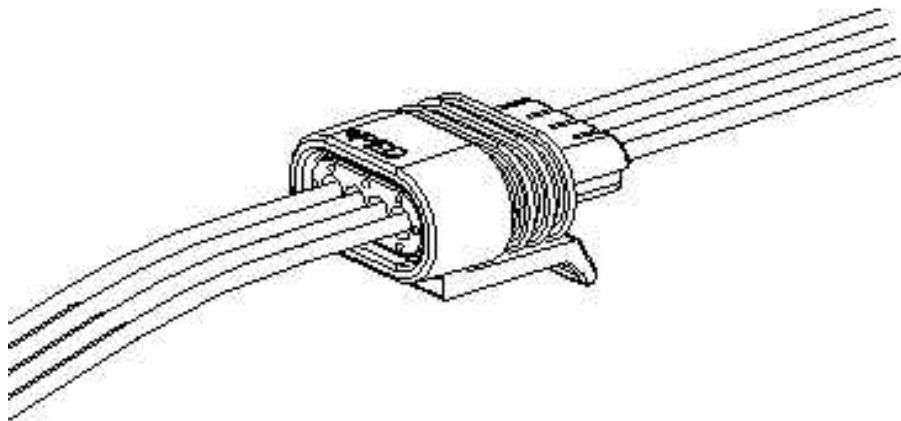

STEP 2: PUSH ALL LEADS THROUGH CABLE SEAL AND OUT THE OTHER END OF CONNECTOR ASSEMBLY. FROM THE BLUNT CUT END OF THE LEADS, PULL ALL LEADS THROUGH CONNECTOR ASSEMBLY A MINIMUM OF (8") FOR EASE IN SUBSEQUENT CABLE INSULATION STRIPPING AND TERMINATING PROCESSES.

ASSEMBLY INSTRUCTIONS PULL-TO-SEAT SEALED CONNECTION SYSTEM

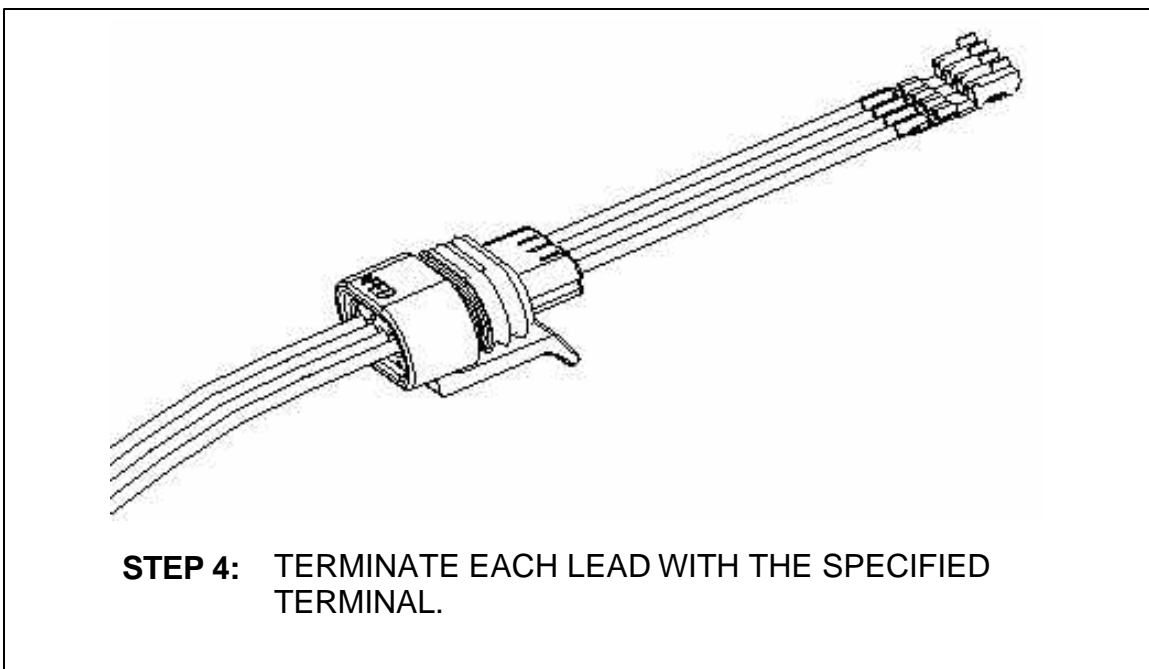
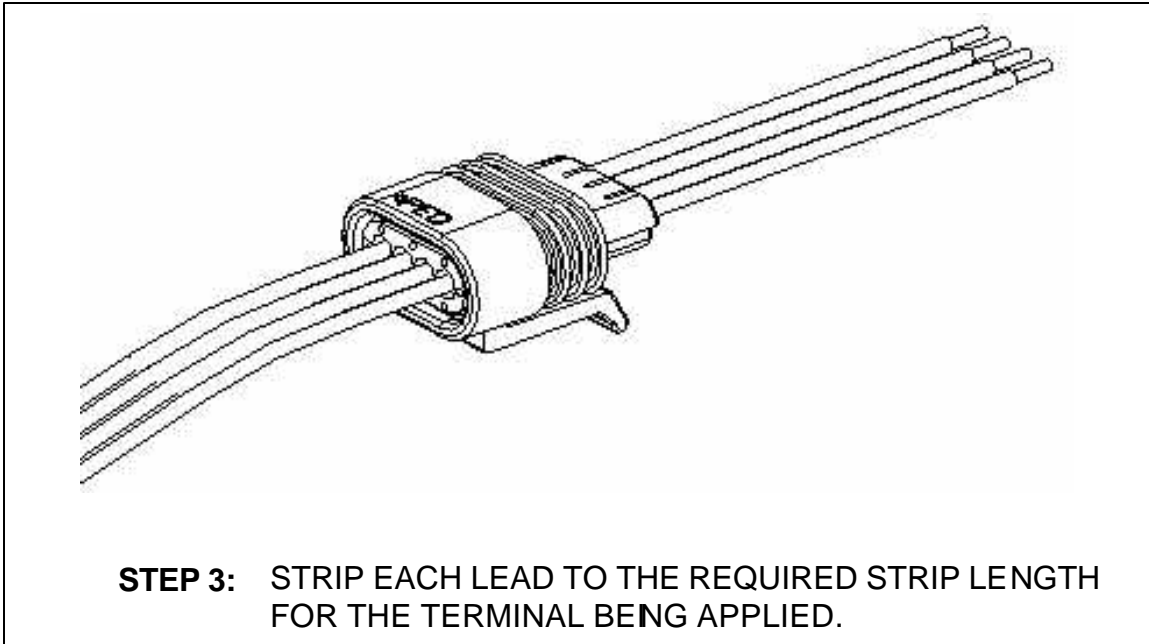

ASSEMBLY INSTRUCTIONS PULL-TO-SEAT SEALED CONNECTION SYSTEM

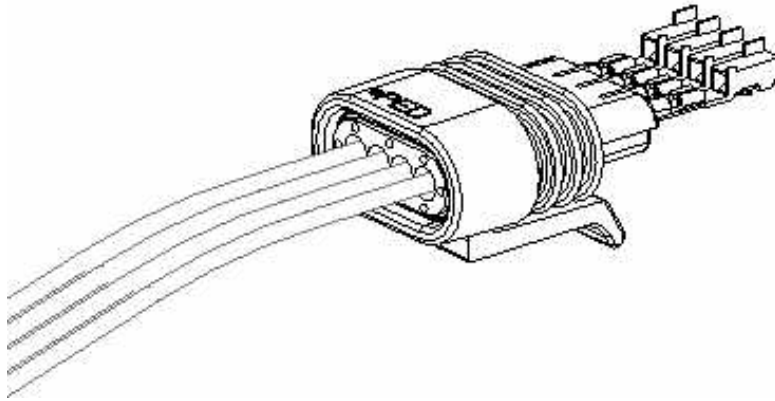

STEP 5: A. PULL TERMINATED LEADS BACK THROUGH CONNECTOR ASSEMBLY TO FULLY SEATED POSITION IN CONNECTOR ASSEMBLY. USE CARE TO ALIGN TERMINAL IN CORRECT ORIENTATION AS IT MOVES INTO TERMINAL CAVITY. VERIFY THE TERMINAL HAS BEEN FULLY SEATED WITH THE AUDIBLE CLICK OF THE TANG.

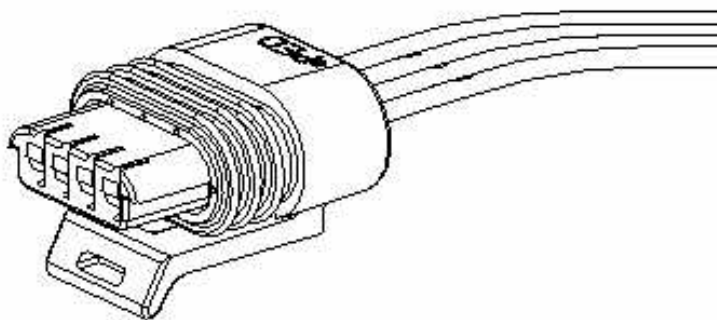

STEP 5: B. VISUALLY VERIFY THE FULLY SEATED TERMINAL AS IT SITS INSIDE THE PLASTIC TERMINAL CAVITY.

ASSEMBLY INSTRUCTIONS PULL-TO-SEAT SEALED CONNECTION SYSTEM

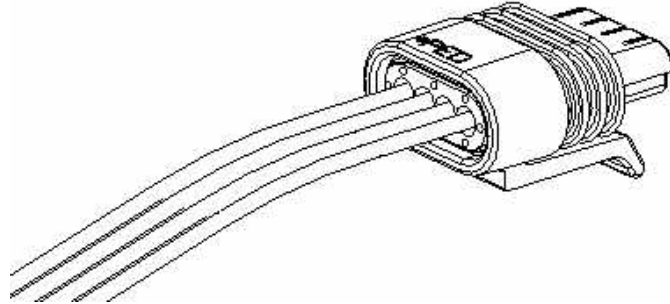

STEP 5: C. IF CABLE SEAL PULLS OUT OF CONNECTOR ASSEMBLY DURING TERMINAL SEATING OPERATION, USE CARE TO PUSH SEAL BACK INTO POSITION IN CONNECTOR ASSEMBLY.